

# 选用说明

## 一、按照负荷选择胀紧套

1. 选择胀紧套应满足:

a. 传递扭矩:  $M_t \geq M$

b. 承受轴向力:  $F_t \geq F_a$

c. 承受径向力:  $p_r \geq \frac{F_r}{d \cdot l} \times 10^3$

式中,  $M_t$ -----胀紧套的额定扭矩,  $\text{kN} \cdot \text{m}$ ;

$M$ -----需传递的扭矩,  $\text{kN} \cdot \text{m}$ ;

$F_t$ -----胀紧套的额定轴向力,  $\text{kN}$ ;

$F_a$ -----需承受的轴向力,  $\text{kN}$ ;

$F_r$ -----需承受的径向力,  $\text{kN}$ ;

$p_r$ -----胀紧套与轴结合面上的压强,  $\text{MPa}$ 。

$d$ 、 $l$ -----胀紧套内径尺寸和内环宽度,  $\text{mm}$ ;

2. 一个联结采用数个胀紧套时的额定负载:

一个胀紧套的额定负荷小于传递的负荷时, 可用两个或两个以上的胀紧套串联使用, 其总额定负荷为:

$$M_m = m \cdot M_t$$

式中:  $M_m$ ----- $n$ 个胀紧套总额定负荷;

$M$ -----负荷系数。(见下表)

联结中胀紧套的数量 $n$	$m$	
	Z1型胀紧套	Z2~Z23型胀紧套
1	1.00	1.0
2	1.56	1.8
3	1.86	2.7
4	2.03	---

## 二、结合面的公差及表面粗糙度

1. 与胀紧套结合的轴和孔, 其公差带按GB 1800-79《公差与配合 总论 标准公差与基本偏差》和

GB 1801《公差与配合 尺寸至500mm 孔、轴公差带与配合》的规定。推荐的孔、轴公差带列于表

胀紧套型式	胀紧套内径 d mm	与胀紧套结合的轴的 公差带	与胀紧套结合的孔的 公差带
Z1	<38	h6	H7
	>38	h8	H8
Z2	所用直径	h7或h8	H7或H8
Z3	所用直径	h8	H8
Z4	所用直径	h9或k9	N9或H9
Z5~Z23	所用直径	h8	H8

2. 与胀紧套结合的轴和孔，其表面粗糙度按GB 1031-83《表面粗糙度 参数及其数值》的规定。推荐的微观不平度+点高度 $R_a$ 列于表

胀紧套型号	微观不平度+点高度 $R_a$ $\mu m$	
	与胀紧套结合的轴	与胀紧套结合的孔
Z1	<1.6	<1.6
Z2~Z23	<3.2	<3.2

### 三、联结件的尺寸

1. 与胀紧套联结的空心轴，其内径 $d_i$ (见图)应满足：

$$d_i \leq d \times \sqrt{\frac{\sigma_s - 2p_r \cdot c}{\sigma_s}}, \text{ mm}$$

- 式中： $\sigma_s$ ----- 空心轴的屈服极限，N/mm<sup>2</sup>；  
 $p_r$ ----- 胀紧套与轴结合面上的压力，N/mm<sup>2</sup>；  
 $d$ ----- 胀紧套内径，mm；  
 $c$ ----- 系数。（见下表）

胀紧套 型式	Z1			Z2		Z3	Z4	Z5
	一个联结中的胀紧套数							
	1	2	>2	1	2			
C	0.6	0.8	1	0.6	0.8	0.8	0.85	0.9

# Selection

## 1、 selection according to load

1. The information for selection;

a. Transmissible torque :  $M_i \geq M$

b. Axial force :  $F_i \geq F_a$

c. Radial force :  $p_i \geq \frac{F_r}{d \cdot l} \times 10^3$

$M_i$ -----Nominal torque of locking assemblies,  $\text{kN} \cdot \text{m}$ ;

$M$ ----- Transmission torque required,  $\text{kN} \cdot \text{m}$ ;

$F_i$ -----Nominal axial force of locking assemblies,  $\text{kN}$ ;

$F_a$ ----- Axial force required,  $\text{kN}$ ;

$F_r$ ----- Radial force required,  $\text{kN}$ ;

$p_i$ -----Pressure of contact surface,  $\text{MPa}$ .

$d, l$ ----Width and inside Dia. of inner ring,  $\text{mm}$ ;

2. The nominal load of several locking assemblies

When transmission load more than the nominal load of locking assemblies, use tow or more locking assemblies to connect ,the total nominal load are:

$$M_{in} = m \cdot M_i$$

that :  $M_{in}$ -----The total nominal load of "n" locking assemblies;

$m$ -----Coefficient of load。 Table of "m"

Quantity of locking assemblies "n"	m	
	Z1 locking assemblies	Z2 to Z23 locking assemblies
1	1.00	1.0
2	1.56	1.8
3	1.86	2.7
4	2.03	---

## 2、 tolerance and roughness of connect surface

1. Shaft and hub bore which connect with locking assemblies, its tolerance is according With the

standard GB 1800-79 and GB 1801. Recommended tolerance of shaft and hub bore as following list

Locking assemblies type	Inner ring dia. d mm	Tolerance of shaft	Tolerance of hub bore
Z1	<38	h6	H7
	>38	h8	H8
Z2	diameter	h7orh8	H7orH8
Z3		h8	H8
Z4		h9ork9	N9orH9
Z5~Z23		h8	H8

2. Shaft and hub bore which connect with locking assemblies. Its roughness is according with the standard GB 1031-83. Recommended roughness of shaft and hub bore as following list

Locking assemblies type	Roughness $R_z$ $\mu m$	
	Roughness of shaft	Roughness of hub bore
Z1	<1.6	<1.6
Z2~Z23	<3.2	<3.2

### 3. Dimension of connecting parts

1. "d<sub>i</sub>", inner dia of hollow axle that connect with locking assemblies :

$$d_i \leq dx \sqrt{\frac{\sigma_s - 2p_r \cdot c}{\sigma_s}}, \text{ mm}$$

that:  $\sigma_s$ -----Yield limit of hollow axle, N/mm<sup>2</sup>;

$p_r$ -----Pressure on shaft, N/mm<sup>2</sup>;

$d$ -----Inner diameter of locking assemblies, mm;

$C$ -----Coefficient. Table of Coefficient "C"

Type	Z1			Z2		Z3	Z4	Z5
	Number of locking assemblies							
	1	2	>2	1	2			
C	0.6	0.8	1	0.6	0.8	0.8	0.85	0.9

# 胀紧联结套安装拆卸的一般要求

## 一、胀紧套的安装

- 1.清洗结合件表面，使之无污物、无腐蚀、无损伤。
- 2.在清洗干净的胀紧套表面和结合件表面上，均匀涂一层薄润滑油。
- 3.把被联结件推移到轴上，使达到设计规定的位置。
- 4.将拧松螺钉的胀紧套平滑地装入联结孔处，要防止结合件的倾斜，然后用手将螺钉拧紧。

## 二、拧紧胀紧套螺钉的方法

- 1.胀紧套螺钉应使用力矩扳手按对角、交叉、均匀的拧紧。

(拧紧顺序如下图所示：)

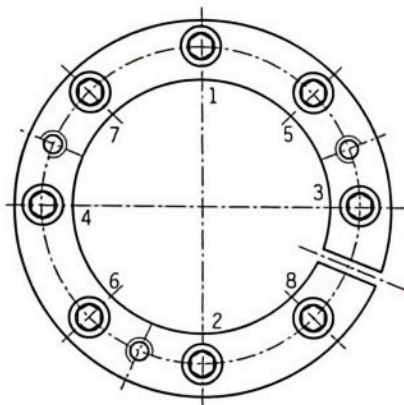

- 2.螺钉的拧紧力矩 $M_A$ 值按选型样本的规定，并按下列步骤逐步拧紧：

- a.以 $1/3 M_A$ 值拧紧；
- b.以 $2/3 M_A$ 值拧紧；
- c.以 $M_A$ 值拧紧；
- d.以 $M_A$ 值检查全部螺钉。

## 三、胀紧套的拆卸

- 1.拆卸时先松开全部螺钉，但不要将螺钉全部拧出。
- 2.取下镀锌的螺钉（垫圈），将拉出的螺钉旋入前压紧环的拆卸螺孔中，轻轻敲击拉出螺钉的头部，使胀紧套松动，然后拉动螺钉即可将胀紧套拉出。

**注：**用于拆卸的螺钉，头部需加工为平端并带倒角。

## 四、防护

- 1.安装完毕后，在胀紧套外露端面及螺钉头部涂上一层防锈油脂。
- 2.露天作业或工作环境较差的机器，应定期在外露的胀紧套端面上涂防锈油脂。
- 3.需在腐蚀介质中工作的胀紧套，应采用专门的防护（如加盖板）以防胀紧套锈蚀。

# Mount and removal

## 1 . Mounting

- 1) Clean the parts that need connect.
- 2) Daub oil or grease on contact surface of shaft , hub bore and locking assemblies .
- 3) Slip the hub onto the shaft , set them at the predetermined position
- 4) Grease the contact locking–bolts surfaces. Slip the locking assemblies onto the shaft, insert bolts into the holes and screw them in by hands

## 2 . Tighten

- 1) tighten locking–bolts as following figure

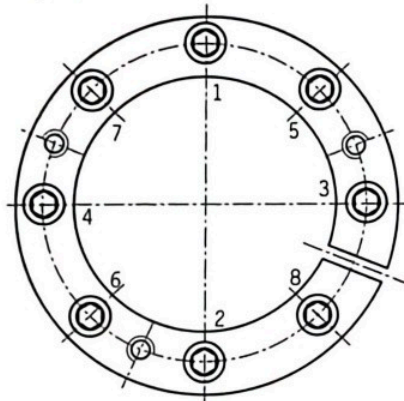

- 2) Increase tighten torque  $M_A$  as following

- a .  $1/3 M_A$
- b .  $2/3 M_A$
- c .  $1 M_A$
- d . use Torque Wrench check torque

## 3 . Removal

- 1) Make sure that no torque or thrust is being applied to the shaft and hub. loosen the locking bolts.

- 2) If the locking assemblies is still locked even after loosening the bolts , insert bolts into the jack screw holes and screw them in until locking assemblies unlocks.

Attention: The bolt can be removed and the top of it need to be process even with 45 degree angle.

## 4 . Protect

- 1) Daub rustproof function oil on surface that open in air after mounting
- 2) When a standard locking assemblies is to be used outdoors, it should be lubricated with grease regularly.
- 3) When a standard locking assemblies is to be used in Corrode medium , it need a professional protect device .

安装参考范例  
Mounting example

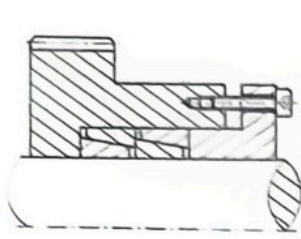

Z1

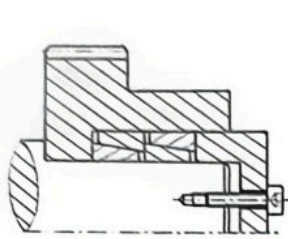

Z2

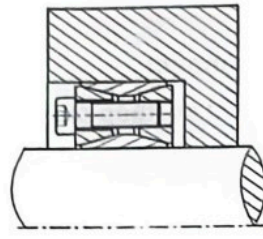

Z3

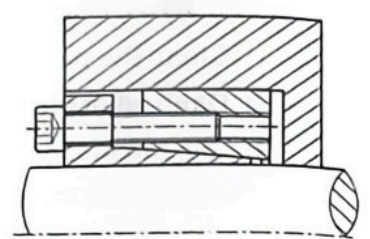

Z4

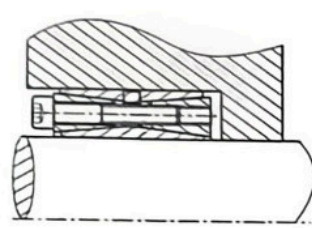

Z5

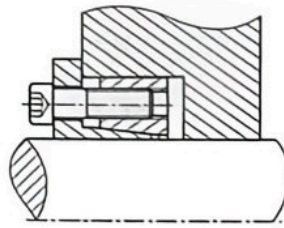

Z6

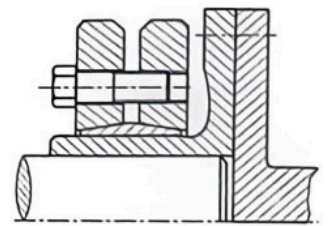

Z7A

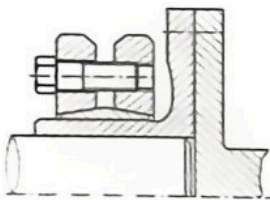

Z7B

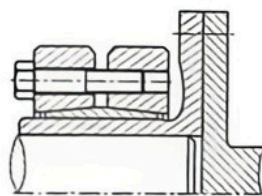

Z7C

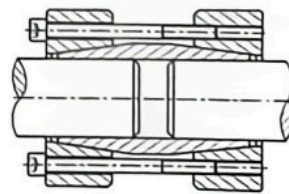

Z7D

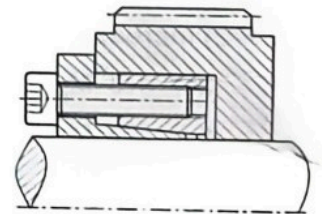

Z8

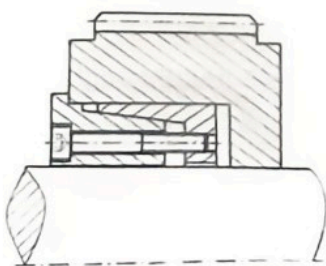

Z9

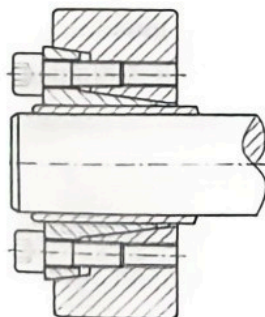

Z10

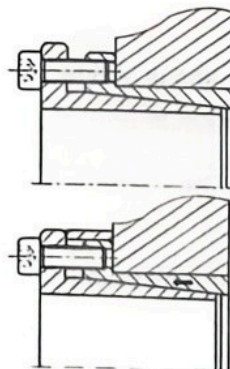

Z11

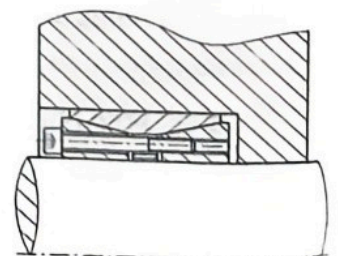

Z12A

安装参考范例  
Mounting example

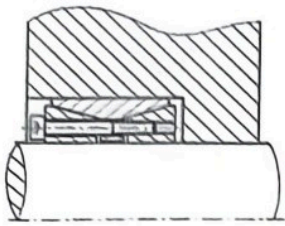

Z12B

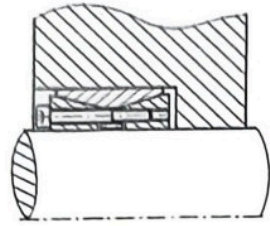

Z12C

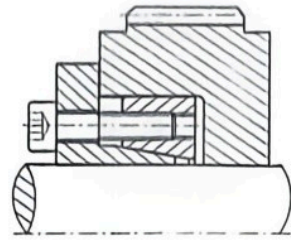

Z13

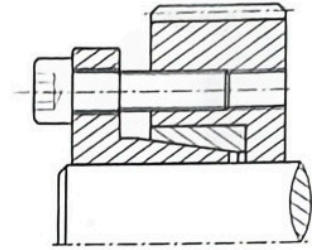

Z14

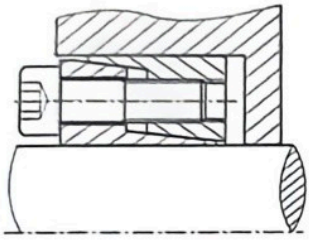

Z15

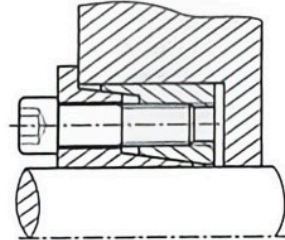

Z16

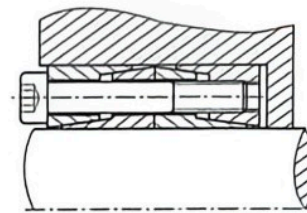

Z17A

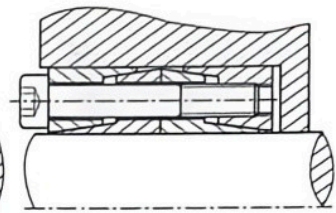

Z17B

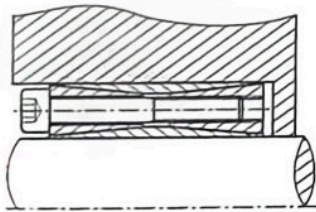

Z18

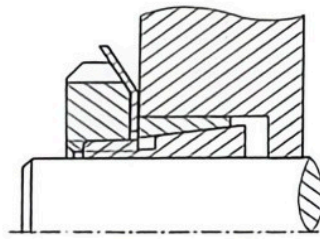

Z19A

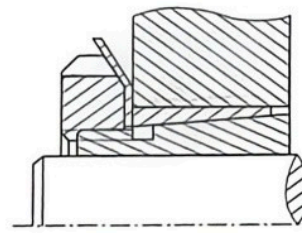

Z19B

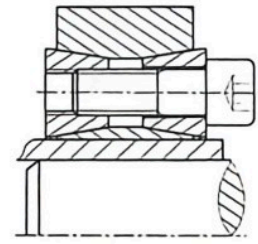

Z20

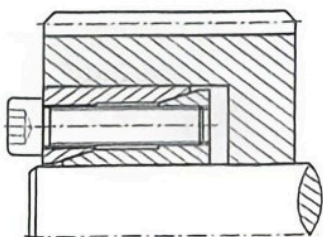

Z21

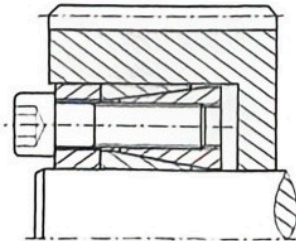

Z22

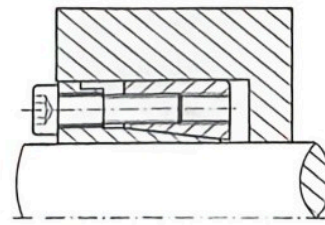

Z23

型号 Z<sub>2</sub>型  
TYPE

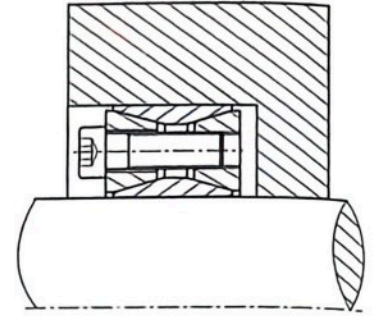
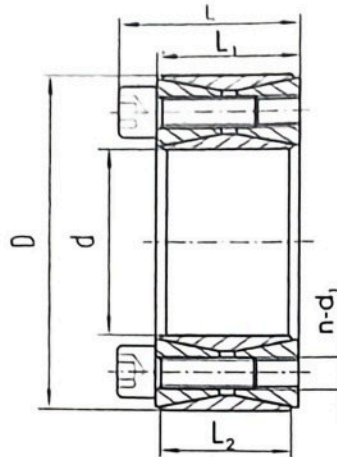

安装示例

基本尺寸 Fundamental dimension					螺钉 bolt		额定负荷 Rated Load		轴结合面 上的压力 pressure on shaft $P_r$ N/mm <sup>2</sup>	毂结合面 上的压力 pressure on hub $P_r'$ N/mm <sup>2</sup>	螺钉的拧紧 力矩 torque of tighten- locking-bolt $M_A$ N·m	重量 Weight kg				
d	D	L	L <sub>1</sub>	L <sub>2</sub>	d <sub>1</sub>	n	轴向力 force $F_t$ kN	扭矩 Torque $M_t$ kN·m								
mm																
20	47	26	20	17	M6	8	27	0.27	210	90	14	0.24				
22	47	26	20	17	M6	8	27	0.3	195	90	14	0.23				
25	50	26	20	17	M6	9	30	0.38	190	95	14	0.25				
28	55	26	20	17	M6	10	33	0.47	185	95	14	0.3				
30	55	26	20	17	M6	10	33	0.5	175	95	14	0.29				
35	60	26	20	17	M6	12	40	0.7	180	105	14	0.32				
38	63	26	20	17	M6	14	46	0.88	185	105	14	0.33				
40	65	26	20	17	M6	14	46	0.92	180	110	14	0.34				
42	72	32	24	20	M8	12	65	1.36	200	117	35	0.48				
45	75	32	24	20	M8	12	72	1.62	210	125	35	0.57				
50	80	32	24	20	M8	12	71	1.77	190	115	35	0.6				
55	85	32	24	20	M8	14	83	2.27	200	130	35	0.63				
60	90	32	24	20	M8	14	83	2.47	180	120	35	0.69				
65	95	32	24	20	M8	16	93	3.04	190	130	35	0.73				
70	110	38	28	24	M10	14	132	4.6	210	130	70	1.26				
75	115	38	28	24	M10	14	131	4.9	195	125	70	1.33				
80	120	38	28	24	M10	14	131	5.2	180	120	70	1.4				
85	125	38	28	24	M10	16	148	6.3	195	130	70	1.49				
90	130	38	28	24	M10	16	147	6.6	180	125	70	1.53				
95	135	38	28	24	M10	18	167	7.9	195	135	70	1.62				
100	145	45	33	29	M12	14	192	9.6	195	135	125	2.01				
105	150	45	33	29	M12	14	190	9.98	185	130	125	2.1				
110	155	45	33	29	M12	14	191	10.5	180	125	125	2.15				
120	165	45	33	29	M12	16	218	13.1	185	135	125	2.35				
125	170	45	33	29	M12	18	220	13.78	180	130	125	2.95				
130	180	50	38	34	M12	20	272	17.6	165	120	125	3.51				
140	190	50	38	34	M12	22	298	20.9	165	125	125	3.85				

型号 Z<sub>2</sub>型  
TYPE

基本尺寸 Fundamental dimension					螺钉 bolt		额定负荷 Rated Load		轴结合面 上的压力 pressure on shaft $P_r$ N/mm <sup>2</sup>	毂结合面 上的压力 pressure on hub $P_r'$ N/mm <sup>2</sup>	螺钉的拧紧 力矩 torque of tighten locking-bolt $M_A$ N·m	重量 Weight kg
d	D	L	L <sub>1</sub>	L <sub>2</sub>	d <sub>1</sub>	n	轴向力 force $F_t$ kN	扭矩 Torque $M_t$ kN·m				
mm												
150	200	50	38	34	M12	24	324	24.2	170	125	125	4.07
160	210	50	38	34	M12	26	350	28	170	130	125	4.3
170	225	58	44	38	M14	22	386	32.8	160	120	190	5.78
180	235	58	44	38	M14	24	420	37.8	165	125	190	6.05
190	250	66	52	46	M14	28	490	46.5	150	115	190	8.25
200	260	66	52	46	M14	30	525	52.5	150	115	190	8.65
210	275	72	56	50	M16	24	599	62.89	151	115	295	10.1
220	285	72	56	50	M16	26	620	68	150	115	295	11.22
240	305	72	56	50	M16	30	715	85.5	160	125	295	12.2
250	315	72	56	50	M16	32	768	96	162	125	295	12.7
260	325	72	56	50	M16	34	800	104	165	130	295	13.2
280	355	84	66	60	M18	32	915	128	145	115	405	19.2
300	375	84	66	60	M18	36	1020	153	150	120	405	20.5
320	405	98	78	72	M20	36	1310	210	150	120	580	29.6
340	425	98	78	72	M20	36	1310	224	145	115	580	31.1
360	455	114	90	84	M22	34	1630	294	145	115	780	42.2
380	475	114	90	84	M22	36	1620	308	135	110	780	44
400	495	114	90	84	M22	36	1610	322	130	105	780	46
420	515	114	90	84	M22	40	1780	374	135	110	780	50
450	555	126	102	96	M24	40	2050	461.25	124	100	1000	65
480	585	126	102	96	M24	42	2160	518.4	124	100	1000	71
500	605	126	102	96	M24	44	2240	560	123	100	1000	72.6
530	640	126	102	96	M24	45	2330	617	121	100	1000	83.6
560	670	126	102	96	M24	48	2440	680	120	100	1000	85
600	710	126	102	96	M24	50	2580	775	118	100	1000	91
630	740	126	102	96	M24	52	2680	844	117	105	1000	94
670	780	126	102	96	M24	56	2820	944	116	100	1000	101
710	820	126	102	96	M24	60	2970	1054	115	100	1000	106
750	860	126	102	96	M24	62	3130	1173	115	100	1000	112
800	910	126	102	96	M24	66	3260	1300	112	100	1000	118
850	960	126	102	96	M24	70	3500	1487	113	100	1000	125
900	1010	126	102	96	M24	75	3680	1650	112	100	1000	132
950	1060	126	102	96	M24	80	3870	1838	112	100	1000	139
1000	1110	126	102	96	M24	82	4000	2000	110	100	1000	146